

Кодировка гайки	Диаметр номинальный	Шаг	Диаметр шарика	N° количество заходов	N° количество контуров	Нагрузка динамическая	Нагрузка статическая	Осевой люфт max.	Тип фланца	Размеры [мм]										
	d_0 [мм]	P_h [мм]	D_w [мм]			C_a [кН]	C_{0a} [кН]	[мм]		D_1	D_4	D_5	D_6	D_7	L_1	L_3	L_7	L_8	L_{10}	L
SFN-D. 16.05.3П	16	5	3.175	1	3	9.0	13.5	0.05	1	28	38	5.5	48	M6	10	5	10	40	8	48
SFN-D. 20.05.3П	20	5	3.175	1	3	10.4	18.4	0.05	1	36	47	6.6	58	M6	10	5	10	44	8	48
SFN-D. 20.05.5П	20	5	3.175	1	5	15.7	28.5	0.05	1	36	47	6.6	58	M6	10	5	10	44	8	63
SFN-D. 20.20.2П	20	20	3.175	1	2	7.0	11.6	0.05	1	36	47	6.6	58	M6	10	5	10	44	8	70
SFN-D. 25.05.3П	25	5	3.175	1	3	12.0	24.4	0.05	1	40	51	6.6	62	M6	10	6	10	48	8	48
SFN-D. 25.06.5П	25	6	3.969	1	5	23.4	44.3	0.06	1	40	51	6.6	62	M6	10	6	10	48	8	67
SFN-D. 25.10.3П	25	10	3.969	1	3	15.6	28.6	0.06	1	40	51	6.6	62	M6	10	6	10	48	8	69
SFN-D. 32.05.4П	32	5	3.175	1	4	17.6	43.9	0.05	1	50	65	9	80	M6	16	6	12	62	8	57
SFN-D. 32.10.3П	32	10	6.350	1	3	28.3	49.6	0.10	1	50	65	9	80	M6	16	6	12	62	8	79
SFN-D. 32.10.4П	32	10	6.350	1	4	36.3	63.5	0.10	1	50	65	9	80	M6	16	6	12	62	8	89
SFN-D. 32.10.5П	32	10	6.350	1	5	44.0	77	0.10	1	50	65	9	80	M6	16	6	12	62	8	100
SFN-D. 32.20.3П	32	20	6.350	1	3	27.9	45.6	0.10	1	50	65	9	80	M6	16	6	12	62	8	112
SFN-D. 32.32.2П	32	32	6.350	1	2	21.2	34.9	0.10	1	56	71	9	86	M6	20	6	14	65	8	91

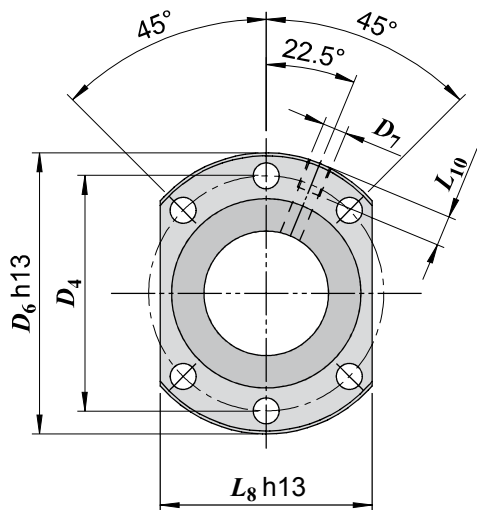

Тип фланца 1
($d_0 < 40$ мм)

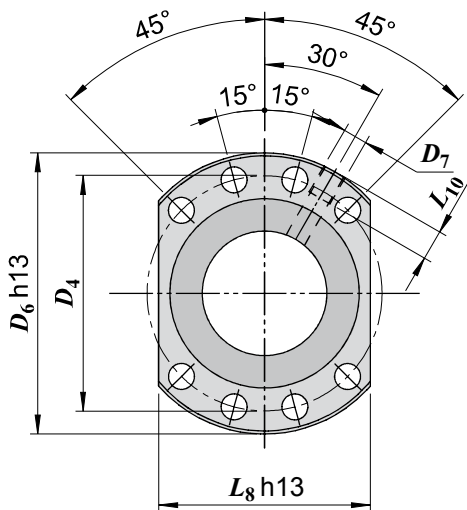

Тип фланца 2
($d_0 > 40$ мм)

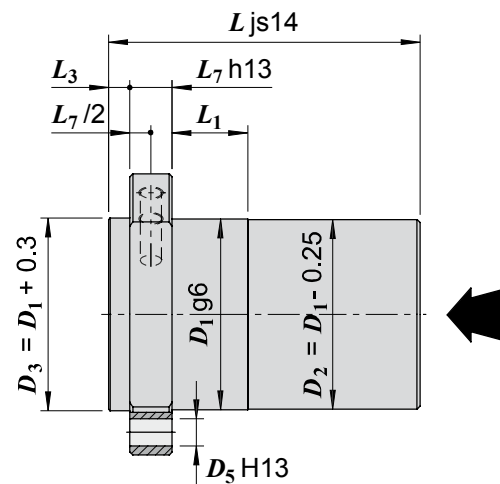

Кодировка гайки	Диаметр номинальный	Шаг	Диаметр шарика	N° количество заходов	N° количество контуров	Нагрузка динамическая	Нагрузка статическая	Осевой люфт max.	Тип фланца	Размеры [мм]										
	d_0 [мм]	P_h [мм]	D_w [мм]			C_a [кН]	C_{0a} [кН]	[мм]		D_1	D_4	D_5	D_6	D_7	L_1	L_3	L_7	L_8	L_{10}	L
SFN-D.40.10.5П	40	10	6.350	1	5	52	157	0.10	2	63	78	9	93	M8×1	16	7	14	70	10	103
SFN-D.40.20.3П	40	20	6.350	1	3	33.4	64	0.10	2	63	78	9	93	M8×1	16	7	14	70	10	115
SFN-D.40.40.2П	40	40	6.350	1	2	24.3	46.2	0.10	2	63	78	9	93	M8×1	25	7	14	70	10	107
SFN-D.50.10.5П	50	10	7.144	1	5	72	163	0.11	2	75	93	11	110	M8×1	16	7	16	85	10	106
SFN-D.50.20.4П	50	20	7.144	1	4	56	121	0.11	2	75	93	11	110	M8×1	16	7	16	85	10	142
SFN-D.63.10.5П	63	10	7.144	1	5	80	209	0.11	2	90	108	11	125	M8×1	16	7	18	95	10	108
SFN-D.63.20.4П	63	20	9.525	1	4	88	191	0.14	2	95	115	13.5	135	M8×1	25	9	20	100	10	155
SFN-D.80.10.6П	80	10	7.144	1	6	112	370	0.11	2	105	125	13.5	145	M8×1	16	9	20	110	10	121
SFN-D.80.16.5П	80	16	9.525	1	5	129	341	0.14	2	125	145	13.5	165	M8×1	25	9	25	130	10	157
SFN-D.80.20.5П-F	80	20	9.525	1	5	145	419	0.14	2	125	145	13.5	165	M8×1	25	9	25	130	10	142
SFN-D.80.20.4П	80	20	12.700	1	4	185	462	0.14	2	125	145	13.5	165	M8×1	25	9	25	130	10	161
SFN-D.100.16.5П	100	16	9.525	1	5	147	454	0.14	2	150	176	17.5	202	M8×1	25	9	30	155	10	165

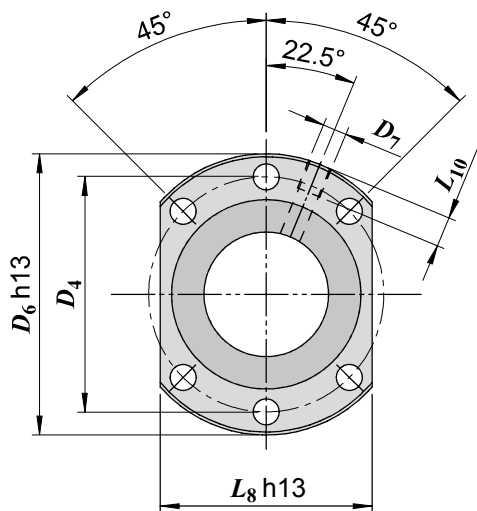

Тип фланца 1
($d_0 < 40$ мм)

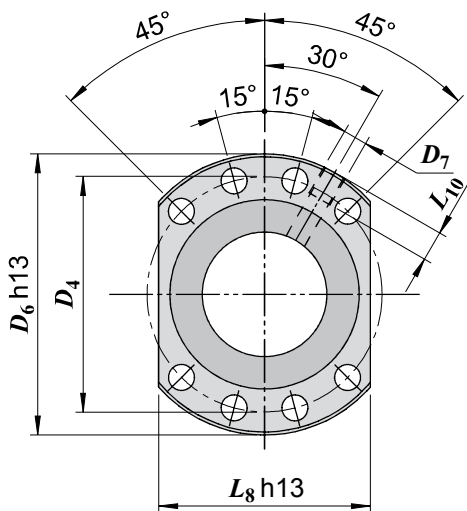

Тип фланца 2
($d_0 > 40$ мм)

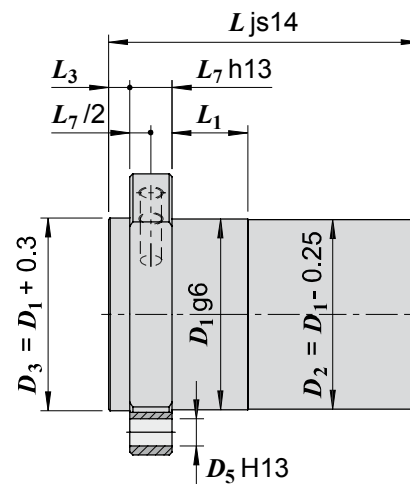

Кодировка гайки	Диаметр номинальный d_0 [мм]	Шаг P_h [мм]	Диаметр шарика D_w [мм]	N° количество заходов	N° количество контуров	Нагрузка динамическая C_a [кН]	Нагрузка статическая C_{0a} [кН]	Осевой люфт max. [мм]	Тип фланца	Размеры [мм]										
										D_1	D_4	D_5	D_6	D_7	L_1	L_3	L_7	L_8	L_{10}	L
SFN-D.16.05.3П	16	5	3.175	1	3	8.1	12.2	0.08	1	28	38	5.5	48	M6	10	5	10	40	8	48
SFN-D.20.05.3П	20	5	3.175	1	3	9.1	16.5	0.08	1	36	47	6.6	58	M6	10	5	10	44	8	48
SFN-D.20.05.5П	20	5	3.175	1	5	14.1	25.6	0.08	1	36	47	6.6	58	M6	10	5	10	44	8	63
SFN-D.25.05.3П	25	5	3.175	1	3	10.8	22.0	0.08	1	40	51	6.6	62	M6	10	6	10	48	8	48
SFN-D.25.06.5П	25	6	3.969	1	5	21.1	39.9	0.10	1	40	51	6.6	62	M6	10	6	10	48	8	67
SFN-D.25.10.3П	25	10	3.969	1	3	14.0	25.7	0.10	1	40	51	6.6	62	M6	10	6	10	48	8	69
SFN-D.32.05.4П	32	5	3.175	1	4	15.8	39.5	0.08	1	50	65	9	80	M6	16	6	12	62	8	57
SFN-D.32.10.3П	32	10	6.350	1	3	25.5	44.6	0.16	1	50	65	9	80	M6	16	6	12	62	8	79
SFN-D.32.10.4П	32	10	6.350	1	4	32.7	57	0.16	1	50	65	9	80	M6	16	6	12	62	8	89
SFN-D.32.10.5П	32	10	6.350	1	5	39.7	69	0.16	1	50	65	9	80	M6	16	6	12	62	8	100
SFN-D.32.20.3П	32	20	6.350	1	3	25.1	41.0	0.16	1	50	65	9	80	M6	16	6	12	62	8	112
SFN-D.40.10.5П	40	10	6.350	1	5	47.1	96	0.16	2	63	78	9	93	M8×1	16	7	14	70	10	103
SFN-D.40.20.3П	40	20	6.350	1	3	30.0	56	0.16	2	63	78	9	93	M8×1	16	7	14	70	10	115

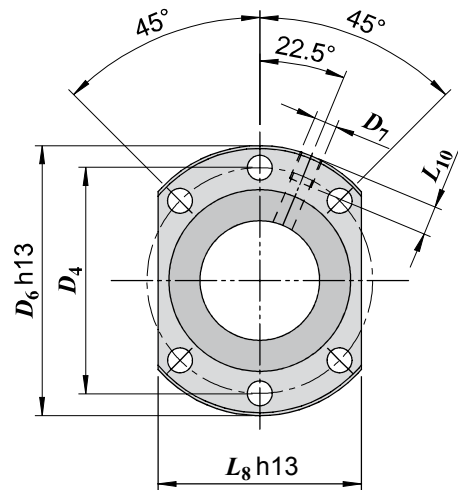
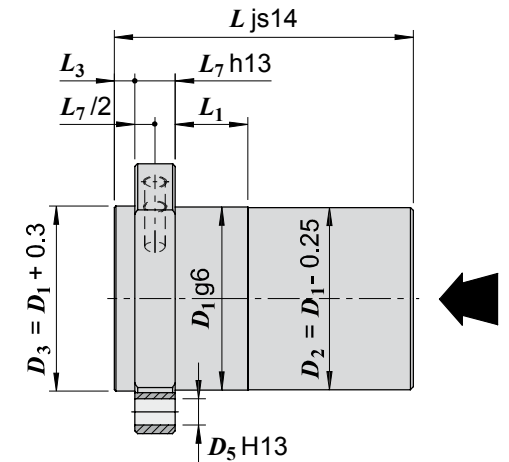
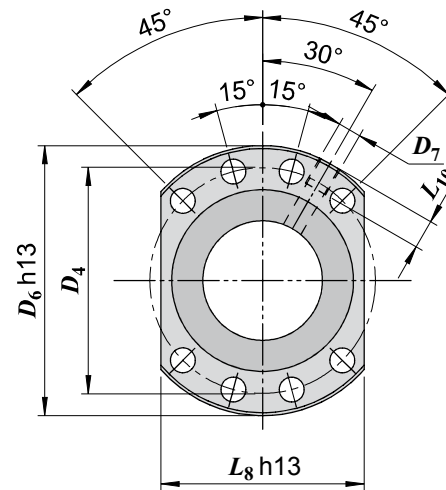
Тип фланца 1
 ($d_0 < 40$ мм)

Тип фланца 2
 ($d_0 > 40$ мм)

Кодировка гайки	Диаметр номинальный d_0 [мм]	Шаг P_h [мм]	Диаметр шарика D_w [мм]	N° заходов	N° контуров	Нагрузка динамическая C_a [кН]	Нагрузка статическая C_{0a} [кН]	Натяг (*) $R_{b/t}$ [Н/мм]	Тип фланца	Размеры [мм]										
										D_1	D_4	D_5	D_6	D_7	L_1	L_3	L_7	L_8	L_{10}	L
SFNP-D.20.05.3П	20	5	3.175	1	3 + 3	10.5	18.5	670	1	36	47	6.6	58	M6	10	5	10	44	8	69
SFNP-D.25.05.3П	25	5	3.175	1	3 + 3	12.0	24.4	830	1	40	51	6.6	62	M6	10	6	10	48	8	69
SFNP-D.25.06.3П	25	6	3.969	1	3 + 3	15.8	28.9	830	1	40	51	6.6	62	M6	10	6	10	48	8	78
SFNP-D.25.10.2П	25	10	3.969	1	2 + 2	11.1	19.2	560	1	40	51	6.6	62	M6	10	6	10	48	8	84
SFNP-D.32.05.4П	32	5	3.175	1	4 + 4	17.6	43.8	1 380	1	50	65	9	80	M6	10	6	12	62	8	82
SFNP-D.32.10.3П	32	10	6.350	1	3 + 3	29.8	50	930	1	50	65	9	80	M6	16	6	12	62	8	119
SFNP-D.40.10.3П	40	10	6.350	1	3 + 3	35.2	69	1 210	2	63	78	9	93	M8×1	16	7	14	70	10	122
SFNP-D.40.10.4П	40	10	6.350	1	4 + 4	45.0	92	1 570	2	63	78	9	93	M8×1	16	7	14	70	10	142
SFNP-D.40.20.2П	40	20	6.350	1	2 + 2	25.7	48.9	850	2	63	78	9	93	M8×1	25	7	14	70	10	145
SFNP-D.50.10.4П	50	10	7.144	1	4 + 4	62	141	2 080	2	75	93	11	110	M8×1	16	7	16	85	10	146
SFNP-D.50.20.2П	50	20	7.144	1	2 + 2	32.5	67	1 010	2	75	93	11	110	M8×1	16	7	16	85	10	152
SFNP-D.63.10.4П	63	10	7.144	1	4 + 4	69	182	1 540	2	90	108	11	125	M8×1	16	7	18	95	10	148
SFNP-D.63.20.2П	63	20	9.525	1	2 + 2	51	104	1 191	2	95	115	13.5	135	M8×1	25	9	20	100	10	165

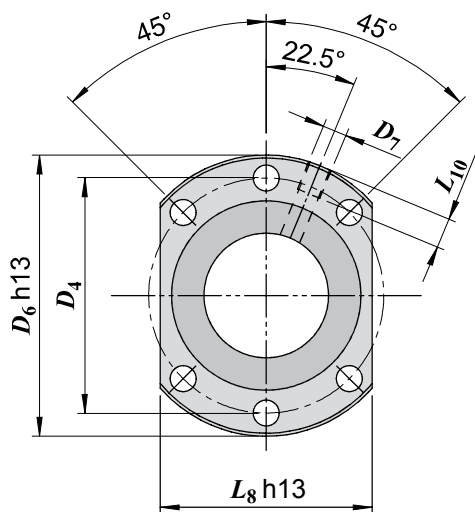
* - значение преднатяга определяется при предварительной нагрузке $F_{pr} = 0.08 \times C_a$

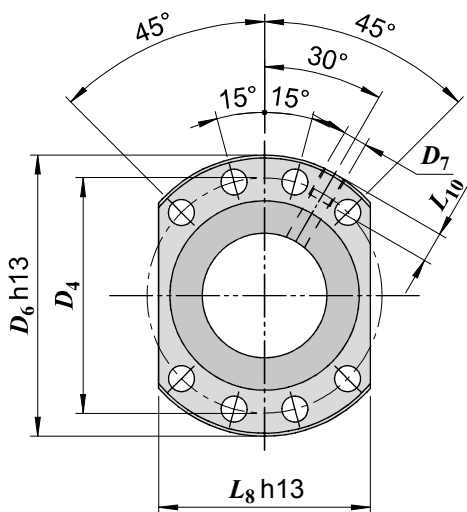

Фланец, тип 1
($d_0 < 40$ мм)



Фланец, тип 2
($d_0 > 40$ мм)

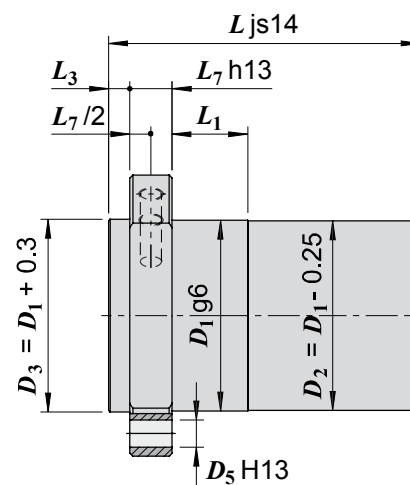

Кодировка гайки	Диаметр номинальный d_0 [мм]	Шаг P_h [мм]	Диаметр шарика D_w [мм]	N° заходов	N° контуров	Нагрузка динамическая C_a [кН]	Нагрузка статическая C_{0a} [кН]	Жесткость (*) $R_{b/t}$ [Н/мкм]	Тип фланца	Размеры [мм]										
										D_1	D_4	D_5	D_6	D_7	L_1	L_3	L_7	L_8	L_{10}	L
DFN-D.20.05.4R	20	5	3.175	1	4 + 4	12.9	23.5	770	1	36	47	6.6	58	M6	10	5	10	44	8	90
DFN-D.25.05.3R	25	5	3.175	1	3 + 3	12.0	24.4	830	1	40	51	6.6	62	M6	10	6	10	48	8	85
DFN-D.25.06.4R	25	6	3.969	1	4 + 4	19.3	36.5	900	1	40	51	6.6	62	M6	10	6	10	48	8	104
DFN-D.25.10.3R	25	10	3.969	1	3 + 3	15.6	28.6	670	1	40	51	6.6	62	M6	10	6	10	48	8	121
DFN-D.32.10.4R	32	10	6.350	1	4 + 4	36.3	62	1 060	1	50	65	9	80	M6	16	6	12	62	8	157
DFN-D.32.20.3R	32	20	6.350	1	3 + 3	27.9	45.6	780	1	50	65	9	80	M6	16	6	12	62	8	205
DFN-D.40.10.5R	40	10	6.350	1	5 + 5	52	107	1 710	2	63	78	9	93	M8×1	16	7	14	70	10	186
DFN-D.40.20.3R	40	20	6.350	1	3 + 3	33.4	64	1 030	2	63	78	9	93	M8×1	25	7	14	70	10	209
DFN-D.50.10.5R	50	10	7.144	1	5 + 5	72	163	2 220	2	75	93	11	110	M8×1	16	7	16	85	10	189
DFN-D.50.20.4R	50	20	7.144	1	4 + 4	56	121	1 680	2	75	93	11	110	M8×1	16	7	16	85	10	267
DFN-D.63.10.6R	63	10	7.144	1	6 + 6	93	252	3 230	2	90	108	11	125	M8×1	16	7	18	95	10	212
DFN-D.63.20.4R	63	20	9.525	1	4 + 4	88	191	1 970	2	95	115	13.5	135	M8×1	25	9	20	100	10	277
DFN-D.80.16.4R	80	16	9.525	1	4 + 4	106	270	2 620	2	125	145	13.5	165	M8×1	25	9	25	130	10	244
DFN-D.100.16.4R	100	16	9.525	1	4 + 4	121	363	3 330	2	150	176	17.5	202	M8×1	25	9	30	155	10	249

* - значение жесткости определяется при предварительной нагрузке $F_{pr} = 0.08 \times C_a$

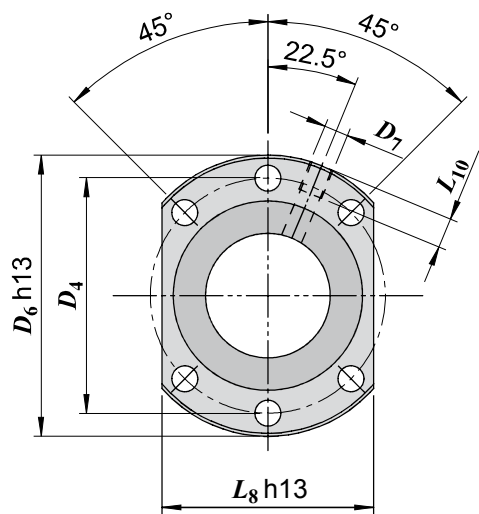

Фланец, тип 1
($d_0 < 40$ mm)

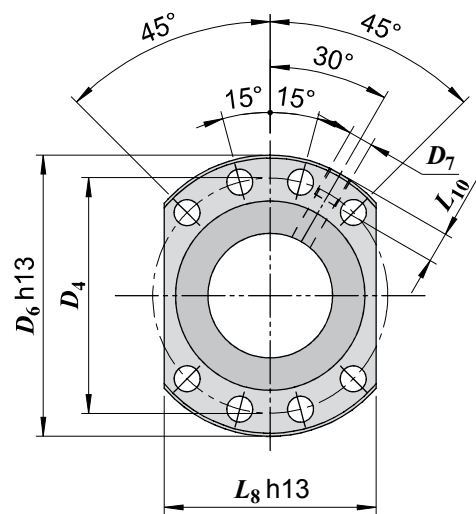

Фланец, тип 2
($d_0 > 40$ mm)

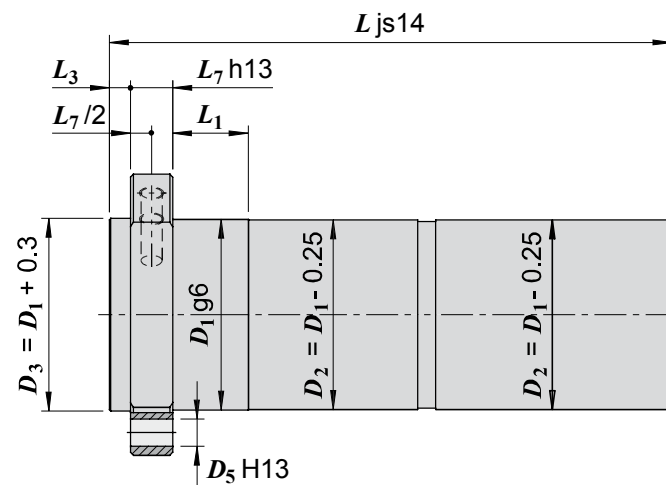

Кодировка гайки	Номинальный диаметр d_0 [мм]	Шаг P_h [мм]	Диаметр шарика D_w [мм]	N° Количество заходов	N° Кол-во контуров	Динамическая нагрузка C_a [кН]	Статическая нагрузка C_{0a} [кН]	Осевой люфт макс. [мм]	Тип фланца	Dimensions [mm]									
										D_1	D_4	D_5	D_6	D_7	L_1	L_3	L_7	L_{10}	L
SFN-S.20.05.3R	20	5	3.175	1	3	10.4	18.4	0.05	1	36	47	6.6	58	M6	10	5	10	8	48
SFN-S.20.05.5R	20	5	3.175	1	5	15.7	28.5	0.05	1	36	47	6.6	58	M6	10	5	10	8	63
SFN-S.20.20.2R	20	20	3.175	1	2	7.0	11.6	0.05	1	36	47	6.6	58	M6	10	5	10	8	70
SFN-S.25.06.5R	25	6	3.969	1	5	23.4	44.3	0.06	1	40	51	6.6	62	M6	10	6	10	8	67
SFN-S.25.10.3R	25	10	3.969	1	3	15.6	28.6	0.06	1	40	51	6.6	62	M6	10	6	10	8	69
SFN-S.32.10.5R	32	10	6.350	1	5	44.0	77	0.10	1	50	65	9	80	M6	16	6	12	8	100
SFN-S.32.20.3R	32	20	6.350	1	3	27.9	45.6	0.10	1	50	65	9	80	M6	16	6	12	8	112
SFN-S.32.32.2R	32	32	6.350	1	2	21.2	34.9	0.10	1	56	71	9	86	M6	20	6	14	8	91
SFN-S.40.10.5R	40	10	6.350	1	5	52	107	0.10	2	63	78	9	93	M8×1	16	7	14	10	103
SFN-S.40.20.3R	40	20	6.350	1	3	33.4	64	0.10	2	63	78	9	93	M8×1	25	7	14	10	115
SFN-S.40.40.2R	40	40	6.350	1	2	24.3	46.2	0.10	2	63	78	9	93	M8×1	25	7	14	10	107
SFN-S.50.10.5R	50	10	7.144	1	5	72	163	0.11	2	75	93	11	110	M8×1	16	7	16	10	106
SFN-S.50.20.4R	50	20	7.144	1	4	56	121	0.11	2	75	93	11	110	M8×1	16	7	16	10	142
SFN-S.63.10.5R	63	10	7.144	1	5	80	209	0.11	2	90	108	11	125	M8×1	16	7	18	10	108
SFN-S.63.20.4R	63	20	9.525	1	4	88	191	0.14	2	95	115	13.5	135	M8×1	25	9	20	10	155
SFN-S.80.16.5R	80	16	9.525	1	5	129	341	0.14	2	125	145	13.5	165	M8×1	25	9	25	10	157
SFN-S.100.16.5R	100	16	9.525	1	5	147	454	0.14	2	150	176	17.5	202	M8×1	25	9	30	10	165

Фланец тип 1

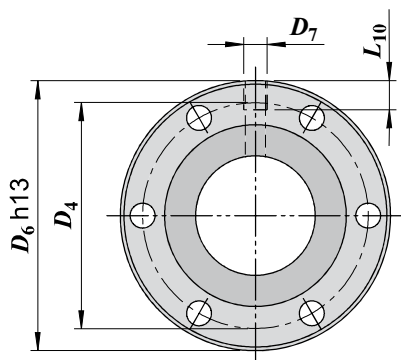
 6 отверстий 60°
 ($d_0 < 40$ mm)

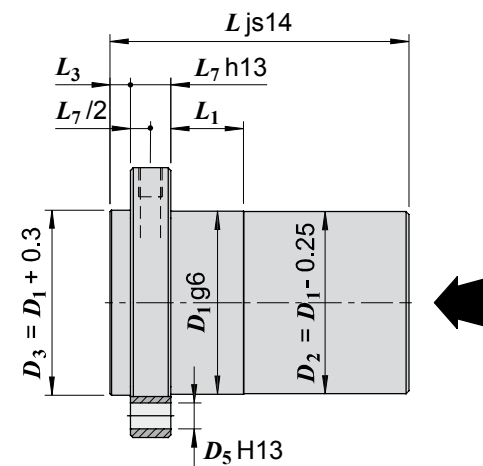
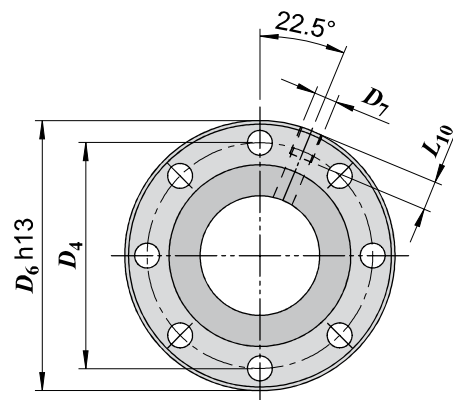
Фланец тип 2

 8 отверстий 45°
 ($d_0 > 40$ mm)

Кодировка гайки	Номинальный диаметр d_0 [мм]	Шаг P_h [мм]	Диаметр шарика D_w [мм]	N° Количество заходов	N° Кол-во контуров	Динамическая нагрузка C_a [кН]	Статическая нагрузка C_{0a} [кН]	Натяг (*) $R_{b/t}$ [Н/мм]	Тип фланца	Размеры [мм]									
										D_1	D_4	D_5	D_6	D_7	L_1	L_3	L_7	L_{10}	L
DFN-S.20.05.4R	20	5	3.175	1	4 + 4	12.9	23.5	770	1	36	47	6.6	58	M6	10	5	10	8	90
DFN-S.25.06.4R	25	6	3.969	1	4 + 4	19.3	36.5	900	1	40	51	6.6	62	M6	10	6	10	8	104
DFN-S.25.10.3R	25	10	3.969	1	3 + 3	15.6	28.6	670	1	40	51	6.6	62	M6	10	6	10	8	121
DFN-S.32.10.4R	32	10	6.350	1	4 + 4	36.3	62	1 060	1	50	65	9	80	M6	16	6	12	8	157
DFN-S.32.20.3R	32	20	6.350	1	3 + 3	27.9	45.6	780	1	50	65	9	80	M6	16	6	12	8	205
DFN-S.40.10.5R	40	10	6.350	1	5 + 5	52	107	1 710	2	63	78	9	93	M8×1	16	7	14	10	186
DFN-S.40.20.3R	40	20	6.350	1	3 + 3	33.4	64	1 030	2	63	78	9	93	M8×1	25	7	14	10	209
DFN-S.50.10.5R	50	10	7.144	1	5 + 5	72	163	2 220	2	75	93	11	110	M8×1	16	7	16	10	189
DFN-S.50.20.4R	50	20	7.144	1	4 + 4	56	121	1 680	2	75	93	11	110	M8×1	16	7	16	10	267
DFN-S.63.10.6R	63	10	7.144	1	6 + 6	93	252	3 230	2	90	108	11	125	M8×1	16	7	18	10	212
DFN-S.63.20.4R	63	20	9.525	1	4 + 4	88	191	1 970	2	95	115	13.5	135	M8×1	25	9	20	10	277
DFN-S.80.16.4R	80	16	9.525	1	4 + 4	106	270	2 620	2	125	145	13.5	165	M8×1	25	9	25	10	244
DFN-S.100.16.4R	100	16	9.525	1	4 + 4	121	363	3 330	2	150	176	17.5	202	M8×1	25	9	30	10	249

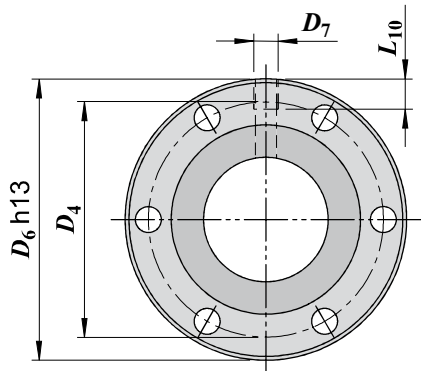
* - значение жесткости определяется при предварительной нагрузке $F_{pr} = 0.08 \times C_a$



Фланец тип 1
6 отверстий 60°
($d_0 < 40$ mm)

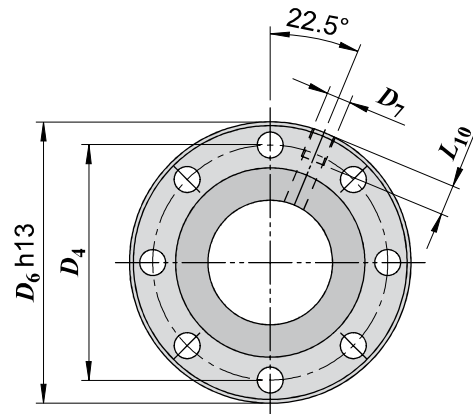

Фланец тип 2
8 отверстий 45°
($d_0 > 40$ mm)

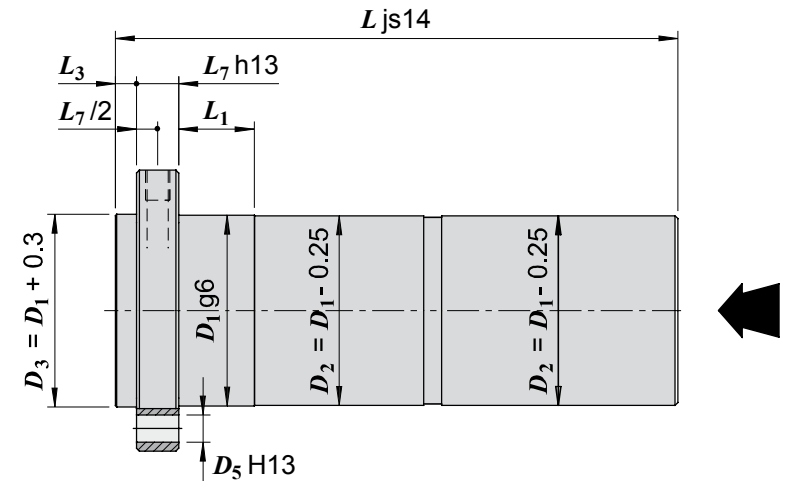

Кодировка гайки	Номинальный диаметр d_0 [мм]	Шаг P_h [мм]	Диаметр шарика D_w [мм]	N° Количество заходов	N° Кол-во контуров	Динамическая нагрузка C_a [кН]	Статическая нагрузка C_{0a} [кН]	Осевой люфт макс. [мм]	Размеры [мм]								
									D_1	D_2	D_3	L_1	L_2	L_3	L_4	L_5	L
SCN-S.20.20.2R	20	20	3.175	1	2	7.0	11.7	0.05	38	M 30×2	32.3	65	20	5	55	1.6	85
SCN-S.25.06.3R	25	6	3.969	1	3	15.1	26.5	0.06	42	M 35×1.5	39.5	35	25	5	26.5	1.85	60
SCN-S.32.10.4R	32	10	6.350	1	4	36.3	62	0.10	50	M 45×1.5	47	95	35	13	74	2.15	130
SCN-S.32.20.2R	32	20	6.350	1	2	19.7	30.4	0.10	50	M 45×1.5	47	95	35	13	74	2.15	130
SCN-S.40.10.5R	40	10	6.350	1	5	52	107	0.10	60	M 55×1.5	57	95	40	13	75	2.15	135
SCN-S.40.20.3R	40	20	6.350	1	3	33.4	64	0.10	60	M 55×1.5	57	115	40	13	95	2.15	155
SCN-S.63.20.4R	63	20	9.525	1	4	88	191	0.14	95	M 80×2	—	120	65	—	—	—	185

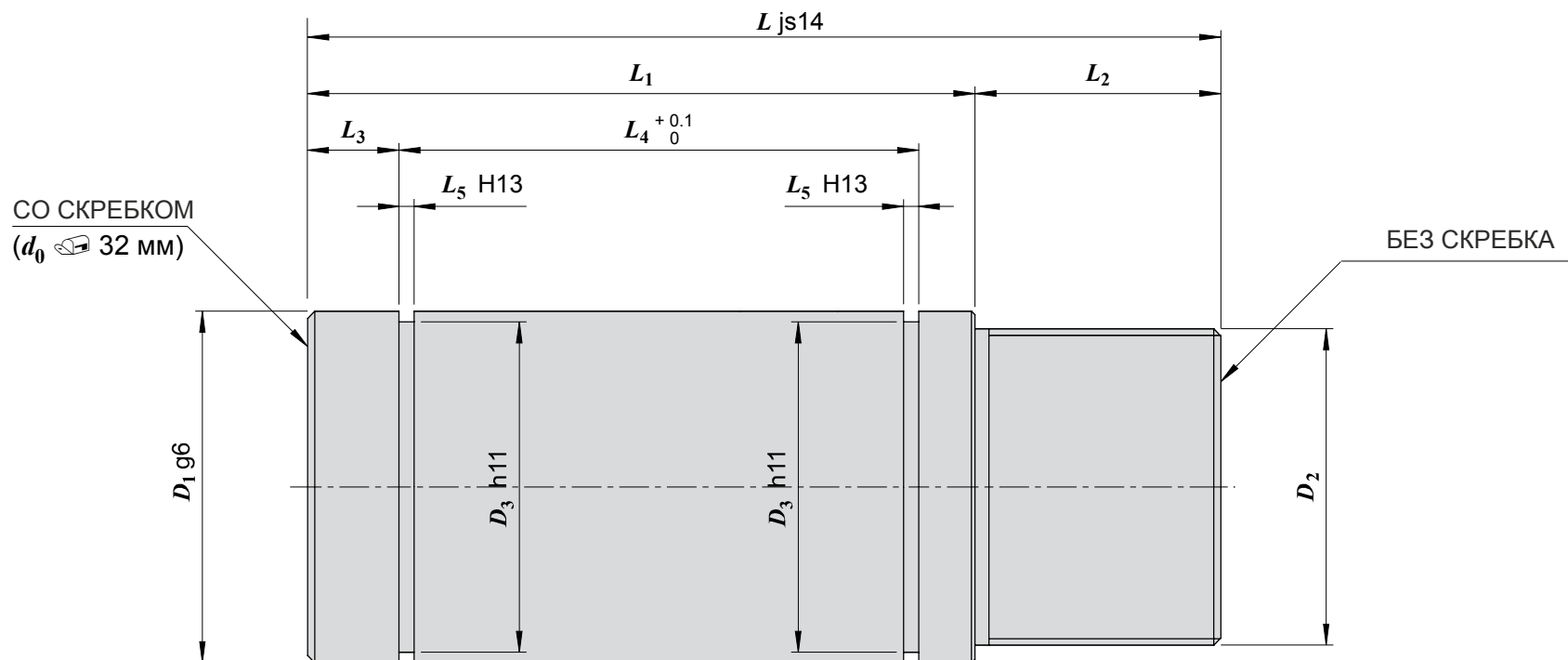

Кодировка гайки	Номинальный диаметр d_0 [мм]	Шаг P_h [мм]	Диаметр шарика D_w [мм]	N° Количество заходов	N° Кол-во контуров	Динамическая нагрузка C_a [кН]	Статическая нагрузка C_{0a} [кН]	Осевой люфт макс. [мм]	Размеры [мм]								
									D_1	D_2	D_3	L_1	L_2	L_3	L_4	L_5	L
SCN-S.14.05.2R	14	5	3.175	1	2	4.9	6.2	0.08	25	M20×1.5	22.9	24	10	4	16.2	1.3	34
SCN-S.14.10.2R	14	10	3.175	1	2	5.3	6.9	0.08	28	M20×1.5	22.9	40	10	4	—	—	50
SCN-S.16.05.3R	16	5	3.175	1	3	7.8	11.4	0.08	30	M25×1.5	28.6	30	16	5	21.5	1.6	46
SCN-S.20.05.3R	20	5	3.175	1	3	9.1	15.4	0.08	34	M30×2	32.3	30	20	5	21.5	1.6	50
SCN-S.20.20.2R	20	20	3.175	1	2	6.3	10.5	0.08	36	M30×2	32.3	65	20	5	55	1.6	85
SCN-S.25.06.3R	25	6	3.969	1	3	13.6	23.9	0.10	42	M35×1.5	39.5	35	25	5	26.5	1.85	60
SCN-S.32.10.4R	32	10	6.350	1	4	32.7	56	0.16	50	M45×1.5	47	95	35	13	74	2.15	130
SCN-S.32.20.2R	32	20	6.350	1	2	17.8	27.4	0.16	50	M45×1.5	47	95	35	13	74	2.15	130
SCN-S.40.10.5R	40	10	6.350	1	5	47.1	96	0.16	60	M55×1.5	57	95	40	13	75	2.15	135
SCN-S.40.20.3R	40	20	6.350	1	3	30.0	57	0.16	60	M55×1.5	57	115	40	13	95	2.15	155

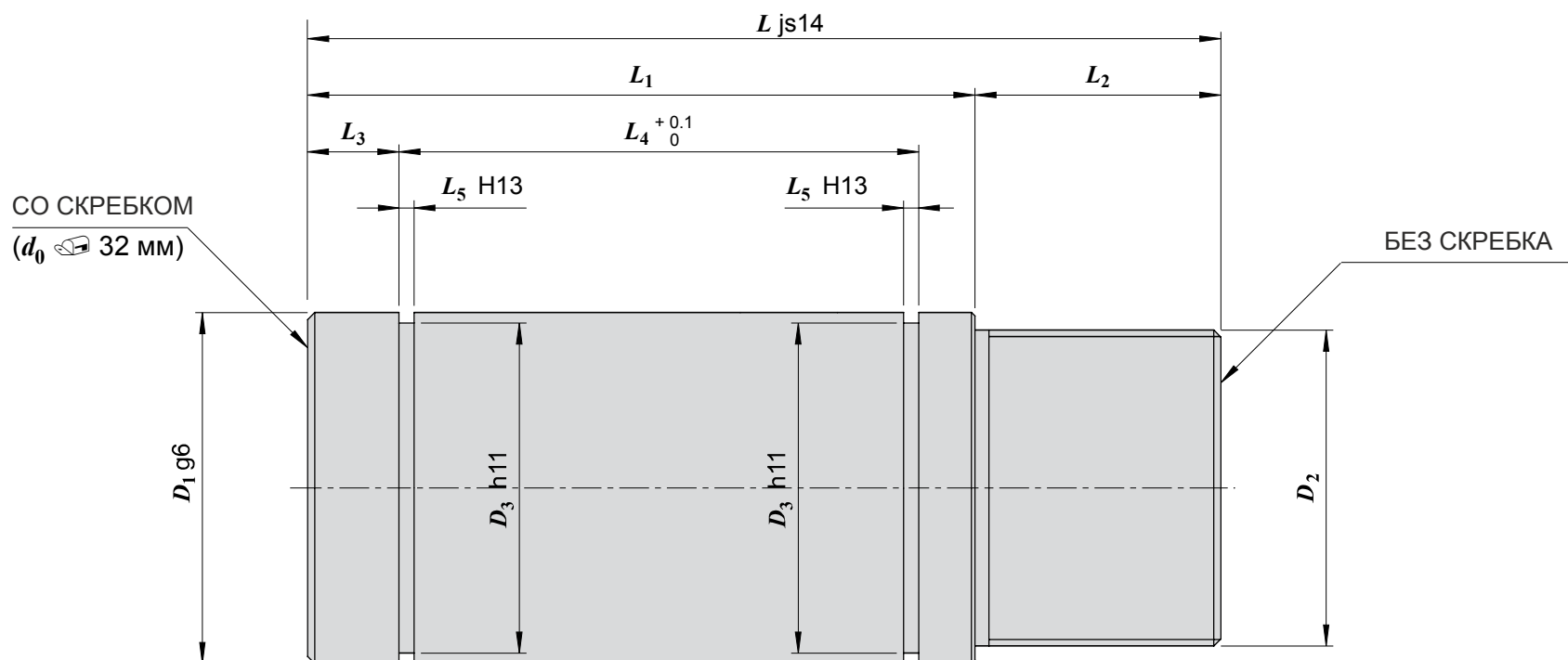

Кодировка гайки	Номинальный диаметр d_0 [мм]	Шаг P_h [мм]	Диаметр шарика D_w [мм]	N° Количество заходов	N° Кол-во контуров	Динамическая нагрузка C_a [кН]	Статическая нагрузка C_{0a} [кН]	Осей люфт макс. [мм]	Размеры [мм]							
									D	D_1	L_1	L_2	L_3	B	H	L
SCN-K.16.05.3R	16	5	3.175	1	3	8.1	12.2	0.08	28	3	10	16	12.5	4	2.3	41
SCN-K.20.05.3R	20	5	3.175	1	4	12.1	22.0	0.08	36	3	10	20	13	5	2.8	46
SCN-K.25.05.3R	25	5	3.175	1	5	16.8	36.6	0.08	40	3	10	20	15.5	5	2.8	51
SCN-K.25.10.3R	25	10	3.969	1	3	14.0	25.7	0.10	40	3	10	25	17.5	5	2.8	60
SCN-K.32.05.5R	32	5	3.175	1	5	19.2	49.3	0.08	50	4	10	16	17.5	6	2.8	51
SCN-K.32.10.4R	32	10	6.350	1	4	32.7	57	0.16	50	4	15	30	26	6	3.3	82
SCN-K.32.20.3R	32	20	6.350	1	3	30.7	56	0.16	56	4	15	35	29	6	3.3	93
SCN-K.40.05.5R	40	5	3.175	1	5	21.3	64	0.08	63	4	10	20	15.5	6	3.8	51
SCN-K.40.10.5R	40	10	6.350	1	5	47.1	96	0.16	63	4	15	35	29	8	3.8	93
SCN-K.40.20.3R	40	20	6.350	1	3	35.3	74	0.16	63	4	15	35	31	8	3.8	97

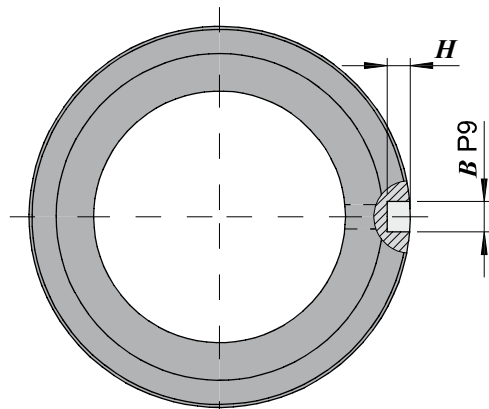
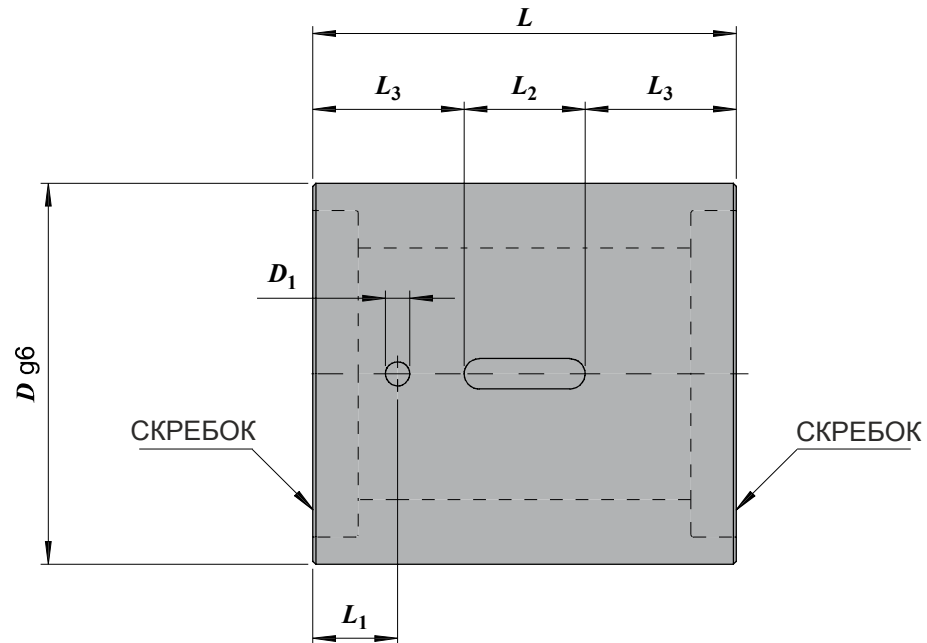

Кодировка гайки	Номинальный диаметр d_0 [мм]	Шаг P_h [мм]	Диаметр шарика D_w [мм]	N° Количество заходов	N° Кол-во контуров	Динамическая нагрузка C_a [кН]	Статическая нагрузка C_{0a} [кН]	Осевой люфт макс. [мм]	Размеры [мм]							
									D_1	D_2	D_3	D_4	L_1	L_2	L_3	L
SCN-T.16.05.3R	16	5	3.175	1	3	8.1	12.2	0.08	34	M30×1.5	6	M6	34	15	10	49
SCN-T.20.05.4R	20	5	3.175	1	4	12.1	22.0	0.08	38	M35×1.5	8	M6	40	16	10	56
SCN-T.25.05.5R	25	5	3.175	1	5	16.8	36.6	0.08	42	M40×1.5	8	M6	44	19	10	63
SCN-T.25.10.3R	25	10	3.969	1	3	14.0	25.7	0.10	42	M40×1.5	8	M6	64	19	15	83
SCN-T.32.05.5R	32	5	3.175	1	5	19.2	49.3	0.08	52	M48×1.5	8	M6	45	19	10	64
SCN-T.32.10.4R	32	10	6.350	1	4	32.7	57	0.16	52	M48×1.5	8	M6	72	19	15	91
SCN-T.40.05.5R	40	5	3.175	1	5	21.3	64	0.08	60	M56×1.5	8	M6	45	19	10	64
SCN-T.40.10.5R	40	10	6.350	1	5	47.1	96	0.16	65	M60×2	8	M8×1	86	24	15	110

